

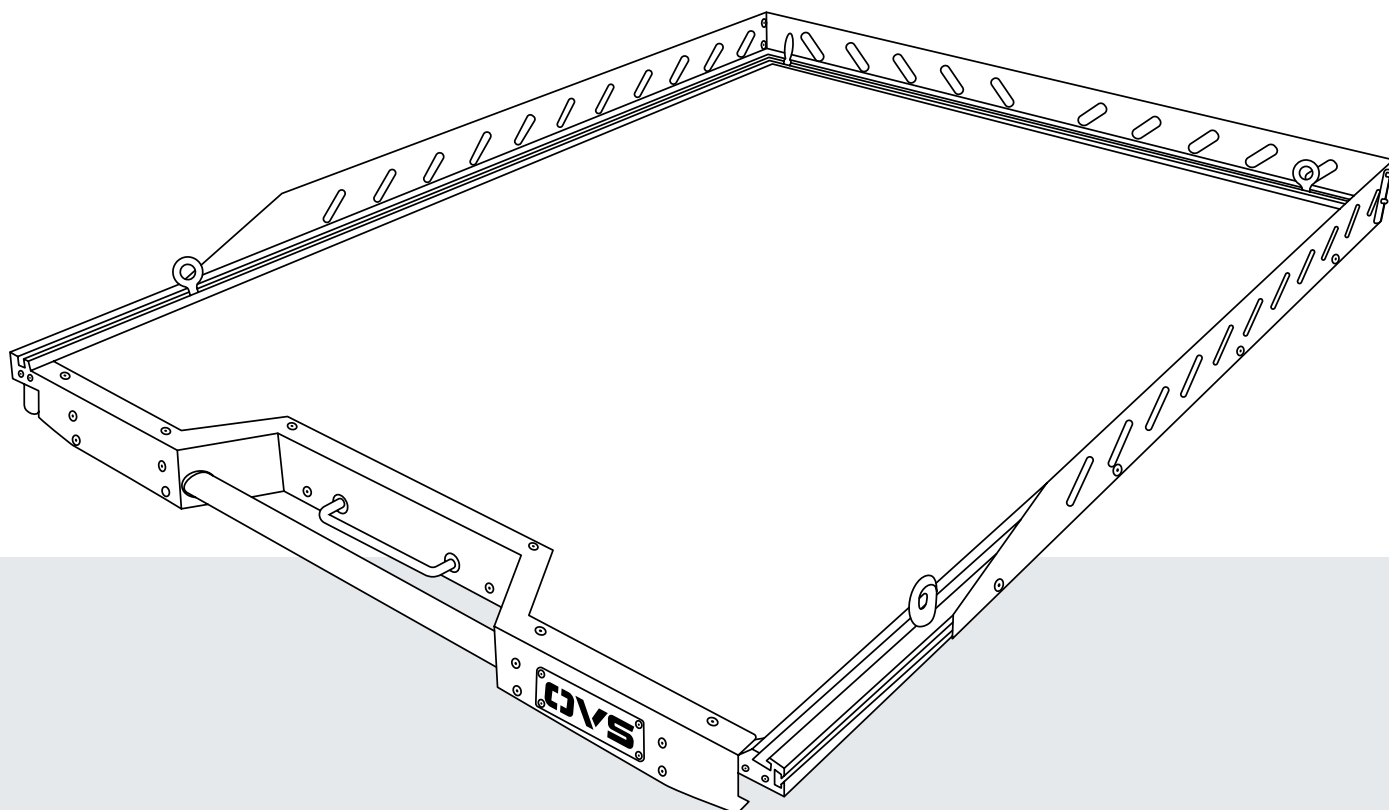

## Bed Extension



**CAREFULLY READ INSTRUCTIONS  
PRIOR TO THE FIRST USE OF THE  
BED EXTENSION**



**ASSEMBLY**

# Bed Extension

SET-UP & CARE INSTRUCTIONS

**\*DO NOT USE IMPACT TOOLS OR OVERTIGHTEN\*** Before drilling holes for Plusnut installations, ensure there are no fuel lines, fuel tanks, batteries, wires, or other obstructions underneath the vehicle that could be damaged in the drilling process.

## GET TO KNOW YOUR BED EXTENSION

### Parts List:

1x Left Side Frame  
1x Right Side Frame  
1x Rear Frame  
16x Button Head Bolts  
11x T Nuts  
4x Hex Nuts  
8x M8 Oversized Washers  
8x M8 x 1.25 Hex Head Bolts  
8x M8 x 1.25 Rivetnuts (Composite/Aluminum)  
8x M8 x 1.25 Rivetnuts (Steel)  
1x M8 x 1.25 Rivetnut Tool

### Tools Needed:

1x Tape Measure  
1x Allen Key  
1x Drill  
1x 1/2" Drill Bit  
1x 7/32" or 13.5 mm Drill Bit  
1x 13mm Wrench  
1x 22mm Wrench  
1x 17mm Wrench

## BED SIDE RAIL ASSEMBLY

\*We recommend to assemble side rails before truck bed installation.

1

To begin, slide in the 4 provided T Nuts into the left or right channels.

Align the left or right plate to the T Nuts and loosely install the 4 button head bolts through the plate to the T Nuts.

**NOTE:** Do Not Tighten.

Repeat for opposite side.

Next, Slide in the 3 Provided T Nuts to the rear channel slide rail.

Align the rear plate to the T Nuts and loosely install the 3 button head bolts through the plate to the T Nuts in the rear channel slide.

Once Loosely installed, insert 4 button head bolts on the corners to secure the side and rear plates together. Use provided M6 hex nuts to secure on inner side.

When all bolts are in position, tighten all button head bolts to T Nuts.

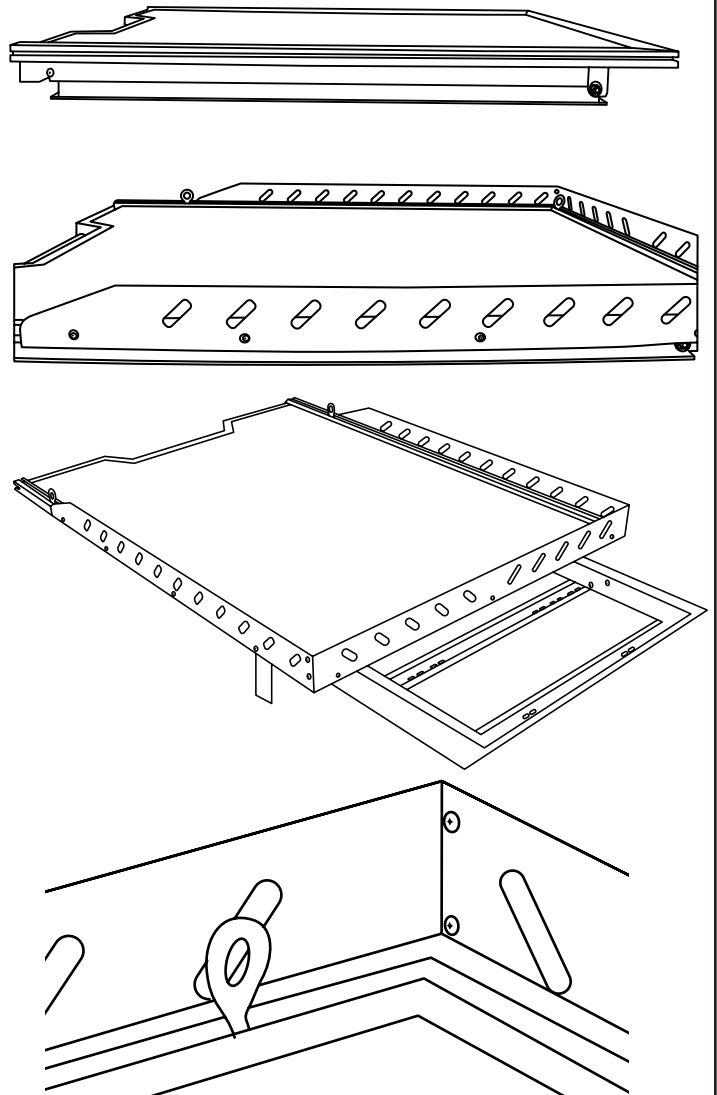

# Bed Extension

## SET-UP & CARE INSTRUCTIONS

**\*DO NOT USE IMPACT TOOLS OR OVERTIGHTEN\*** Before drilling holes for Plusnut installations, ensure there are no fuel lines, fuel tanks, batteries, wires, or other obstructions underneath the vehicle that could be damaged in the drilling process.

2

Slide in the T Nut to the channel.

Screw in the Anchor Points loosely.

Move the Anchor Point to your desired position and tighten to secure. Unscrew to change position depending on cargo.

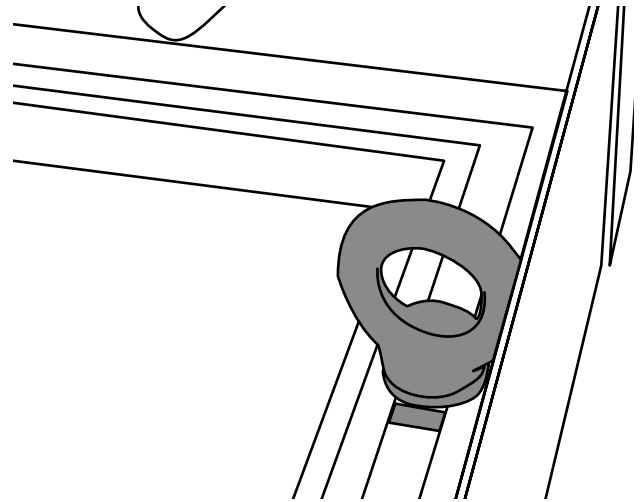
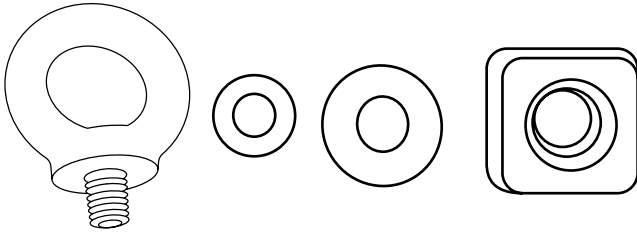

3

With the help of another person, slide the Bed Extension onto the truck bed directly in the center of the bed. Align and center Bed Extension evenly between wheel wells and leave a minimum of 1 1/2" of clearance between bulkhead. Close the tailgate and make sure there is an adequate clearance.

Open tailgate and reconfirm measurements.

Align drill holes to the ridges of your truck.

Mark all drill holes onto the ridges of the truck.

Reconfirm drill markings before next step.

Remove Bed Extension from Truck Bed in order to drill all marked holes.

**NOTE:** Determine what type of bed you have.

**Steel Truck Bed:** If you have a steel bed, insert the provided Rivetnuts into the drill holes. Use a 17/32 (13mm) Drill Bit.

**Composite/Aluminum Truck Bed:** If you have a Composite/Aluminum Bed use the provided Rivetnuts into the drill holes. Use a 1/2" Drill Bit.



TRUCK BED RIDGE

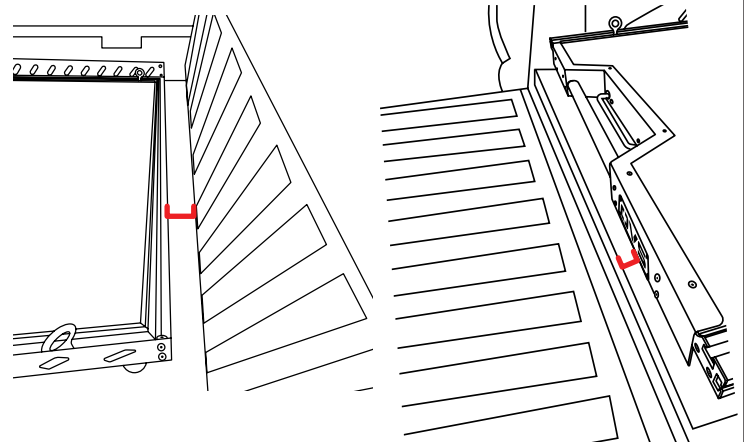

\*Your bed layout may differ from Illustrations

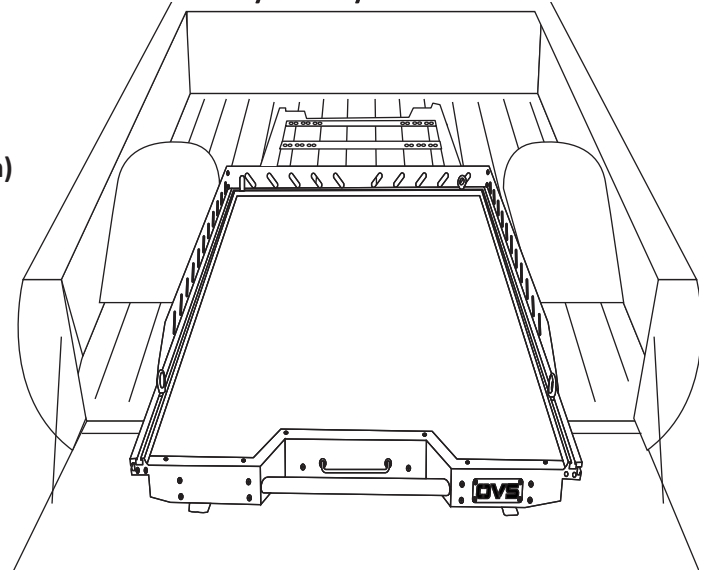

# Bed Extension

## SET-UP & CARE INSTRUCTIONS

**\*DO NOT USE IMPACT TOOLS OR OVERTIGHTEN\*** Before drilling holes for Plusnut installations, ensure there are no fuel lines, fuel tanks, batteries, wires, or other obstructions underneath the vehicle that could be damaged in the drilling process.

4

The Rivet Nut hand tool is comprised of 3 parts.

- Upper Body (the smaller body piece)
- Lower Body
- Socket Head Cap Screw

Put socket head cap screw through tool in the orientation shown in the picture. Then thread rivet nut on the screw until it rests against the underside of the bottom. Insert rivet nut in hole of application while threaded on tool. Use 7/8" Wrench to keep bottom body from turning. Next, put a 11/16" socket over the body turn it clockwise. It will thread top body out of the bottom body. This lifts on the threads of rivet nut, and collapses it. Which forms a bubble on backside holding the rivet nut. Continue turning wrench until it stops. Reverse socket to break the tension in tool. Remove the socket and thread screw out installed rivet nut. Screw top body in bottom before installing.

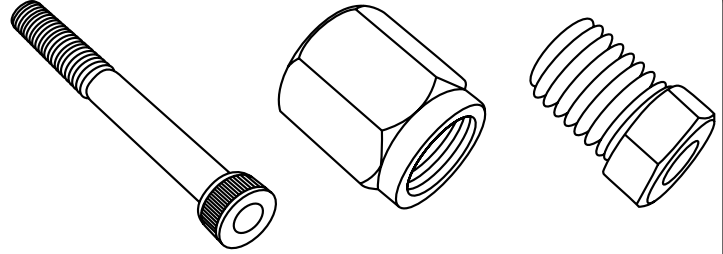

SCAN OR CLICK TO WATCH VIDEO

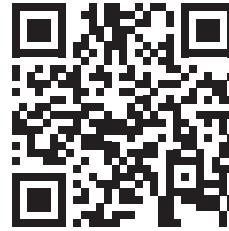

5

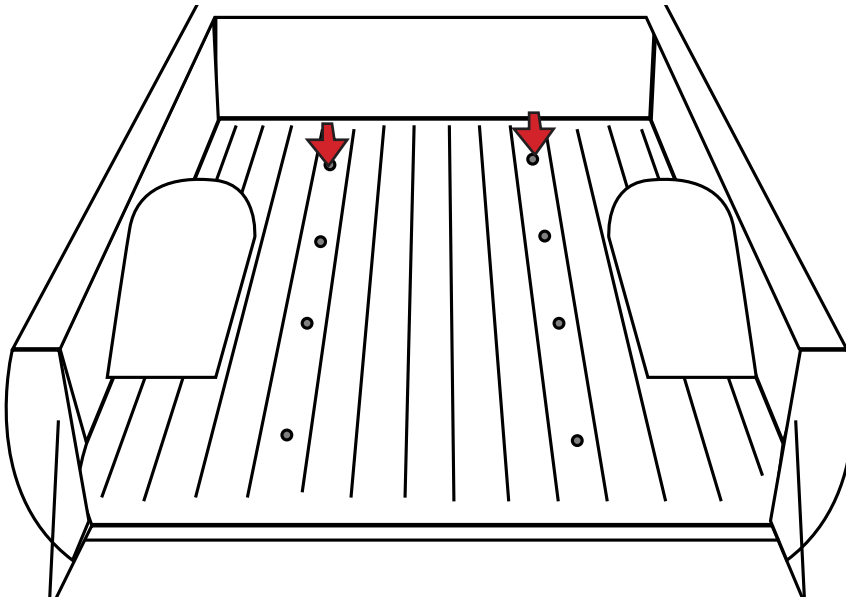

M8 X 1.25" BOLT

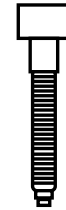

RIVETNUT TOOL



RIVETNUT ANCHOR



TRUCK BED RIDGE



Once the Rivet Nuts are placed onto the tray, insert M8 Oversized Washers and M8 x 1.25 Hex Head Bolts loosely, then tighten once all bolts are inserted.

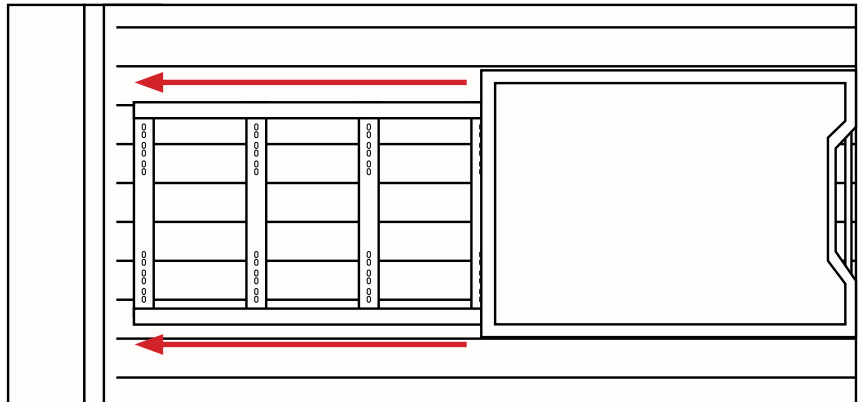

# Bed Extension

## SET-UP & CARE INSTRUCTIONS

**\*DO NOT USE IMPACT TOOLS OR OVERTIGHTEN\*** Before drilling holes for Plusnut installations, ensure there are no fuel lines, fuel tanks, batteries, wires, or other obstructions underneath the vehicle that could be damaged in the drilling process.

### CLEANING

Do not use any type of polish or wax that may contain abrasives that could damage the finish. Mild soap may be used to clean the Bed Extension

### STORING

Store in a cool and dry area, when not in use.

### PAYLOAD

This Bed Extension is only able to carry 1250 LBS.

## WARNINGS

- IT IS ESSENTIAL THAT ALL OVERLAND VEHICLE SYSTEMS PRODUCTS ARE PROPERLY AND SECURELY ASSEMBLED AND ATTACHED TO YOUR VEHICLE. FAILURE TO DO SO MAY LEAD TO AN AUTOMOBILE ACCIDENT, RESULTING IN SERIOUS INJURY OR DEATH.
- YOU ARE RESPONSIBLE FOR ASSEMBLING AND SECURING ALL OVERLAND VEHICLE SYSTEMS PRODUCTS TO YOUR VEHICLE, REGULARLY CHECKING ATTACHMENTS BEFORE USE, AND PERIODICALLY INSPECTING FOR WEAR, DAMAGE, OR NECESSARY ADJUSTMENTS.
- IT IS CRITICAL THAT YOU READ AND FULLY UNDERSTAND ALL INSTRUCTIONS AND SAFETY PRECAUTIONS PROVIDED WITH YOUR OVERLAND VEHICLE SYSTEMS PRODUCT PRIOR TO INSTALLATION OR USE. IF YOU DO NOT FULLY COMPREHEND THE INSTRUCTIONS OR LACK MECHANICAL EXPERIENCE, IT IS STRONGLY RECOMMENDED THAT YOU SEEK ASSISTANCE FROM A PROFESSIONAL INSTALLER OR OTHER QUALIFIED PERSONNEL
- OVERLAND VEHICLE SYSTEMS IS NOT RESPONSIBLE FOR ANY DAMAGE RESULTING FROM IMPROPER INSTALLATION OF THE PRODUCT. IF YOU HAVE QUESTIONS REGARDING INSTALLATION, PLEASE CONTACT US FOR ASSISTANCE.
- BEFORE DRILLING HOLES FOR PLUSNUT INSTALLATIONS, ENSURE THERE ARE NO FUEL LINES, FUEL TANKS, BATTERIES, WIRES, OR OTHER OBSTRUCTIONS UNDERNEATH THE VEHICLE THAT COULD BE DAMAGED IN THE DRILLING PROCESS.
- DO NOT INSTALL ON BED LINER OR BED MAT.



## DO YOU NEED OUR HELP?



CUSTOMER SUPPORT 833-226-4863



SALES@OVERLANDVEHICLESYSTEMS.COM

WANT TO SHOW US YOUR RIG?  
CHECK OUT OUR SOCIAL!

@overlandvehiclesystems

