

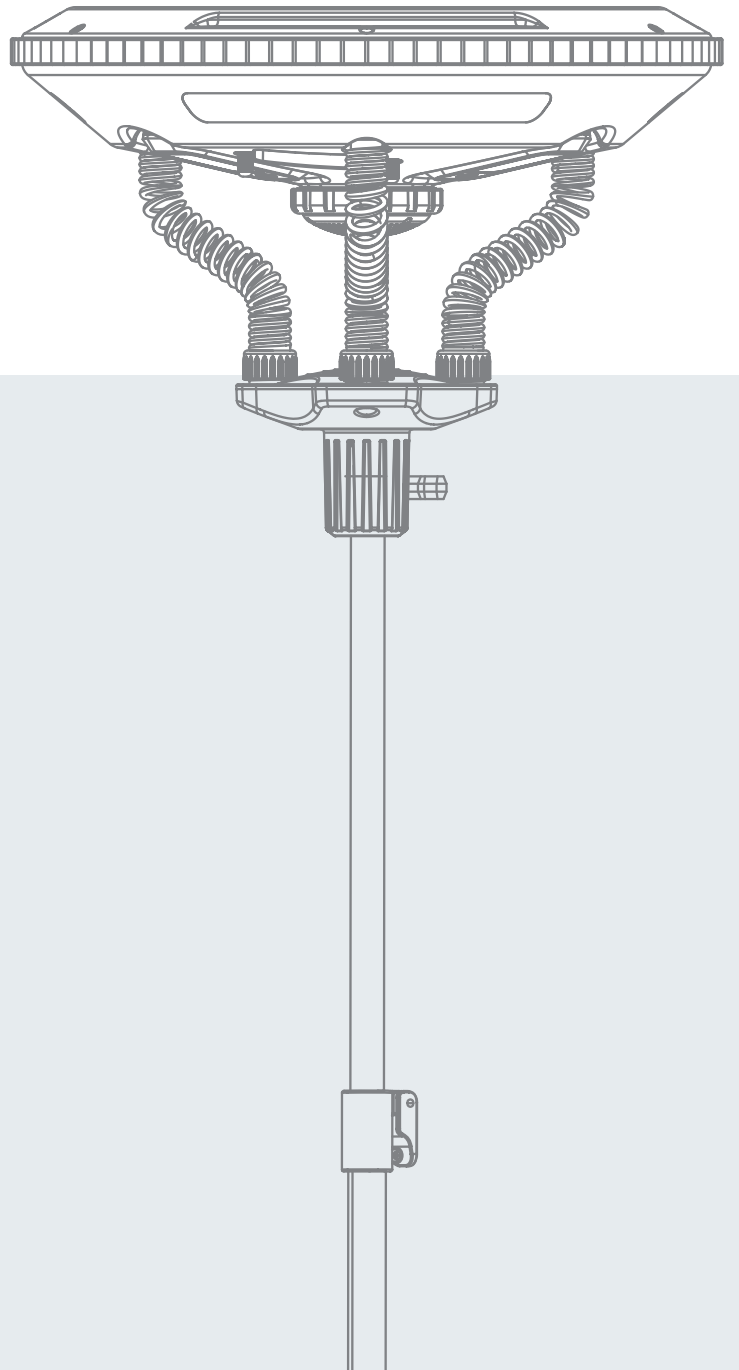

## UFO Solar Camp Light & Speaker

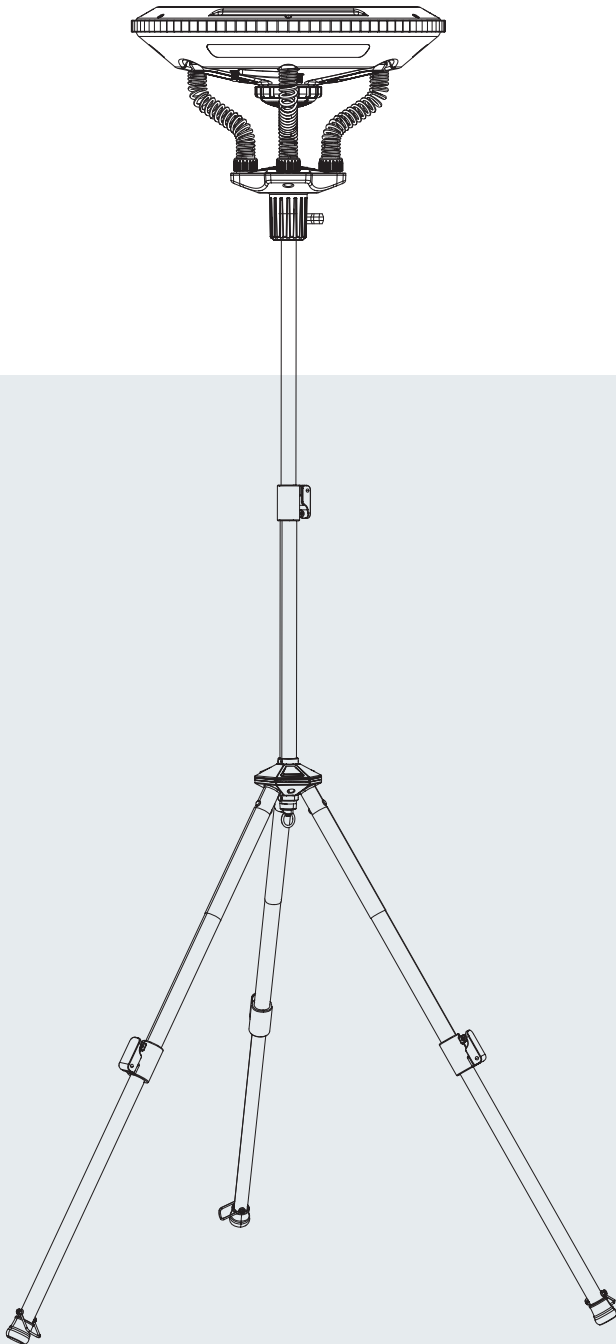

# INSTRUCTION MANUAL

- + Please read these instructions in its entirety before use.
- + Please keep this manual, so it can be referenced in the future.
- + Only with full knowledge of this product can it be used correctly.
- + In a moving vehicle, always store the UFO Speaker/Lamp inside its storage container on the floor of the vehicle either behind the 1st row of seats or behind the 2nd row of seats.

## I. PRODUCT SPECIFICATION

- |                               |   |
|-------------------------------|---|
| 1. Main lamp specifications   | 3 |
| 2. Side lamp specifications   | 3 |
| 3. Portable Bluetooth speaker | 3 |

## II. PRODUCT DETAILS

- |                                    |   |
|------------------------------------|---|
| 1. Whole Equipment Details         | 4 |
| 2. Main lamp details               | 5 |
| 3. On/Off operation                | 5 |
| 4. UFO component details           | 6 |
| 5. Charging instructions           | 6 |
| 6. Side lamp details               | 7 |
| 7. Side lamp charging instructions | 7 |
| 8. Bluetooth Speaker               | 8 |
| 8. Parts and accessories           | 8 |

## III. INSTALLATION INSTRUCTIONS

- |                              |      |
|------------------------------|------|
| I. Installation instructions | 9-11 |
| V . Function and usage range | 12   |
| VI . Notes                   | 12   |

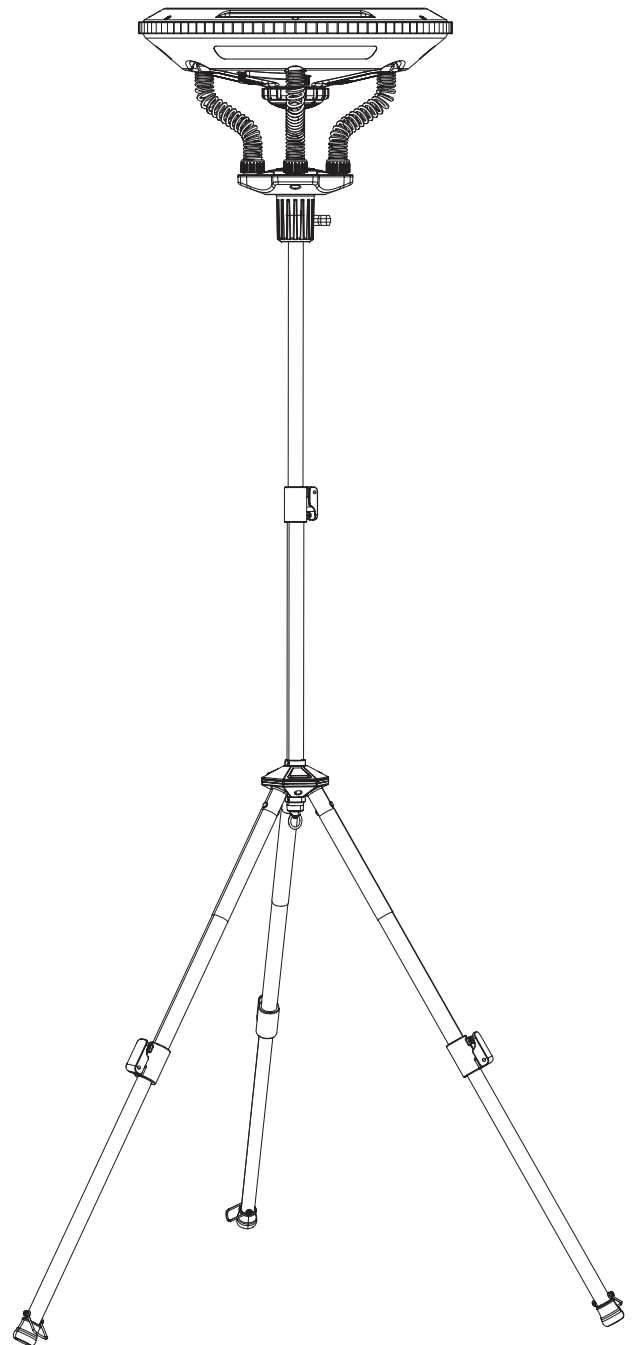
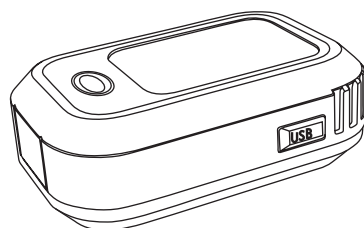

# MAIN LAMPS SPECIFICATIONS

<b>Solar panel specifications:</b>	5.5V/1.3A (248x248) Polysilicon
<b>Main lamp Li-ion battery capacity:</b>	3. 7V 10400mAh
<b>Main lamp power(W):</b>	6.5W/4.5W/3.2W
<b>Main lamp luminous(LM):</b>	700lm/480lm/350lm
<b>Main lamp usage time:</b>	BH/11 H/14H(Li-ion)
<b>Solar charging time:</b>	16H
<b>DC charging time:</b>	10H
<b>USB input:</b>	5V/2A (Compatible adapter)
<b>USB output:</b>	5V/1A
<b>Whole lamp height:</b>	1.5m-2.1 m(Height adjustable)
<b>Color rendering index:</b>	RaB0
<b>Color temperature:</b>	6500K
<b>Lamp life(Hours):</b>	20,000hrs
<b>Working humidity(%):</b>	<95%
<b>Working temperature('C):</b>	-20'C-60'C
<b>Shell material:</b>	Flame retardant ABS
<b>Ingress protection(IP):</b>	IP43

## SIDE LAMP SPECIFICATIONS (MOSQUITO REPELLENT FUNCTION)

<b>Battery capacity(mAh):</b>	3.7V 1800mAh
<b>Reading light Power (W):</b>	1/0.6W/1W
<b>Reading light Luminous flux (lm):</b>	100/50/901m
<b>Reading light mode Duration:</b>	6/8/6H
<b>Spotlight (flashing) Power:</b>	1/0.BW
<b>Spotlight Luminous flux (lm):</b>	BO Lumens
<b>Recharging time:</b>	5 Hours
<b>Working Temp.:</b>	-20° C ~60° C

## BLUETOOTH SPEAKER

<b>Bluetooth version:</b>	Bluetooth V4.2
<b>Signal range:</b>	1 0 meters
<b>Music playing time:</b>	3H ( Max vol )
<b>Rated power:</b>	5 watts
<b>Charging time:</b>	4H
<b>Working voltage:</b>	Li-ion battery inside 3. 7V 11 00mAh
<b>Compatibility:</b>	IOS,Android

# UFO Camp Light & Speaker

SET-UP & CARE INSTRUCTIONS

Full Kit: 15049901

## PRODUCT DETAILS

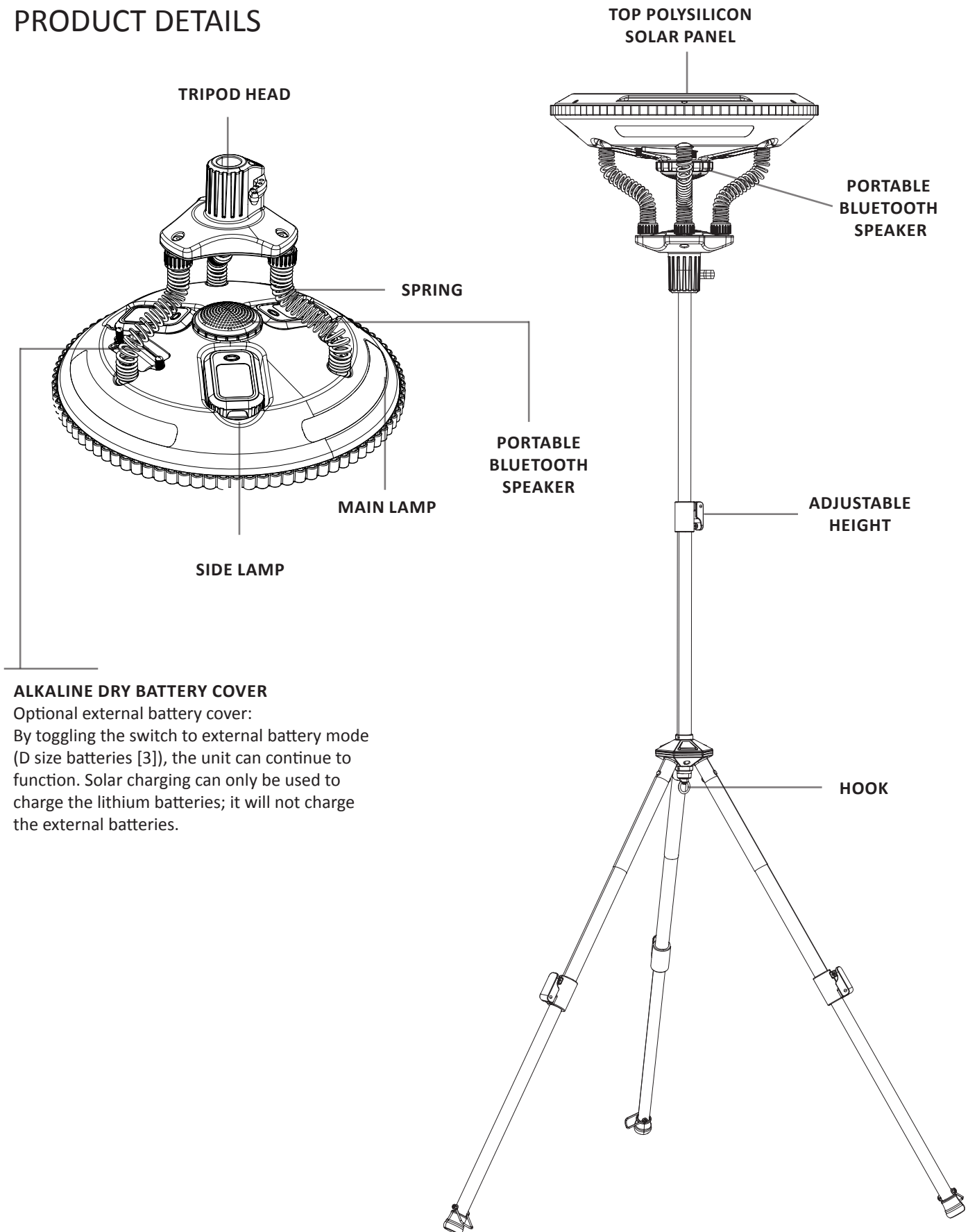

### ALKALINE DRY BATTERY COVER

Optional external battery cover:

By toggling the switch to external battery mode (D size batteries [3]), the unit can continue to function. Solar charging can only be used to charge the lithium batteries; it will not charge the external batteries.

## MAIN LAMP FEATURES

1. The main lamp and side lamp will be charged while charging with DC input or Solar power in sufficient power stats.
2. Main lamp has double color indicator(red and green),the states as follows:

LIGHTING STATS		CHARGING	
POWER	INDICATOR	POWER	INDICATOR
0~25%	Red blinking	0~40%	Red blinking
25%-50%	Red on	40%-70%	Yellow Blinking
50%-75%	Yellow on	70%-95%	Green Blinking
75%-100%	Green on	95%-100%	Green on

Note: For better battery life, please keep charging more than 1 hour after the indicator green light is on

## MAIN EQUIPMENT ON/OFF OPERATION:

- A: Press main switch for more than 2 sec.  
 B: Change light brightness by pressing the main switch 3 times quickly (High, medium and low)

1. PRESS ON/OFF BUTTON (>2 sec.)

MAIN LAMP IN HIGH BRIGHTNESS

2. QUICKLY PRESS THE ON/OFF BUTTON (0.5 sec.-1 sec.)

MAIN LAMP IN MED BRIGHTNESS

3. QUICKLY PRESS THE ON/OFF BUTTON (0.5 sec.-1s sec.)

MAIN LAMP IN LOW BRIGHTNESS

PRESS (>2 sec.) ON/OFF BUTTON AT ANY STATES, THE MAIN LAMP WILL POWER OFF

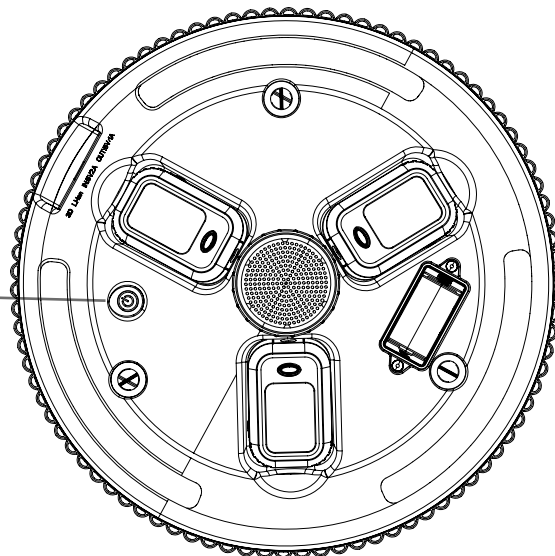

QUICKLY PRESS THE ON/OFF BUTTON, CAN RECYCLE THE ABOVE FUNCTIONS (STATE 1 TO STATE 3)

## UFO COMPONENT DETAILS

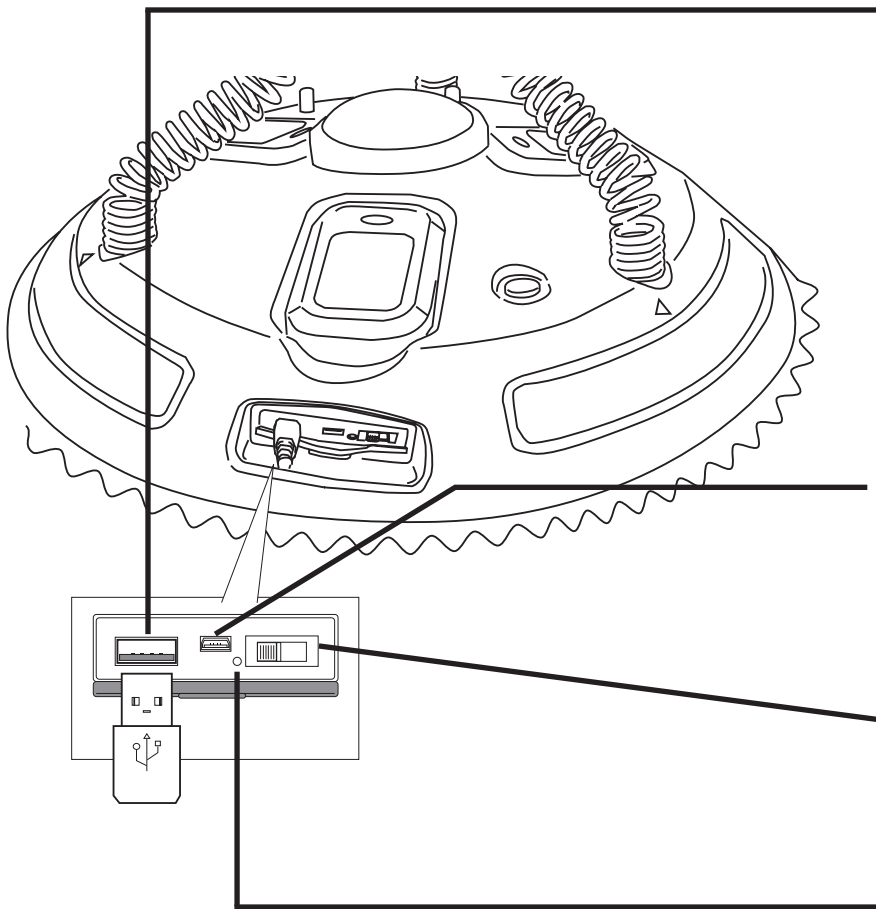

### USB OUTPUT INTERFACE

Can charge for mobile phone and other electronic equipment (5V/2A), with automatic identification, when an external device is connected, the power will be supplied automatically. When the external device is removed, the USB output will be turned off in 20 seconds.

### DC POWER SUPPLY INTERFACE

Insert external USB adapter to charge UFO.

### BATTERY SWITCH

You can choose what power source to use by toggling the switch from solar to external battery.

### MAIN LAMP INDICATOR LIGHT

## UFO COMPONENT DETAILS

To ensure that the lithium battery is fully charged, please charge the battery one (1) extra hour after the green charging indicator has turned on.

1. Charge the equipment with mobile phone power adapter (5V/2A)
2. Use vehicle power (5V/2A) to charge to equipment
3. Solar power can charge the UFO wherever there is bright sunlight. It's designed perfectly for outdoor use.
4. The UFO Solar Camp Light is easy to use and easy to charge.  
Either connect to power using the USB port or let it sit in the sun.

**Notice:** Lithium battery will only charge when main power switch is in solar power option. When lithium batteries fall below 3.0V all outputs will be disabled and enter into shutdown mode or low voltage protection. This is done to protect the lithium battery from complete discharge.

## SIDE LAMP DETAILS

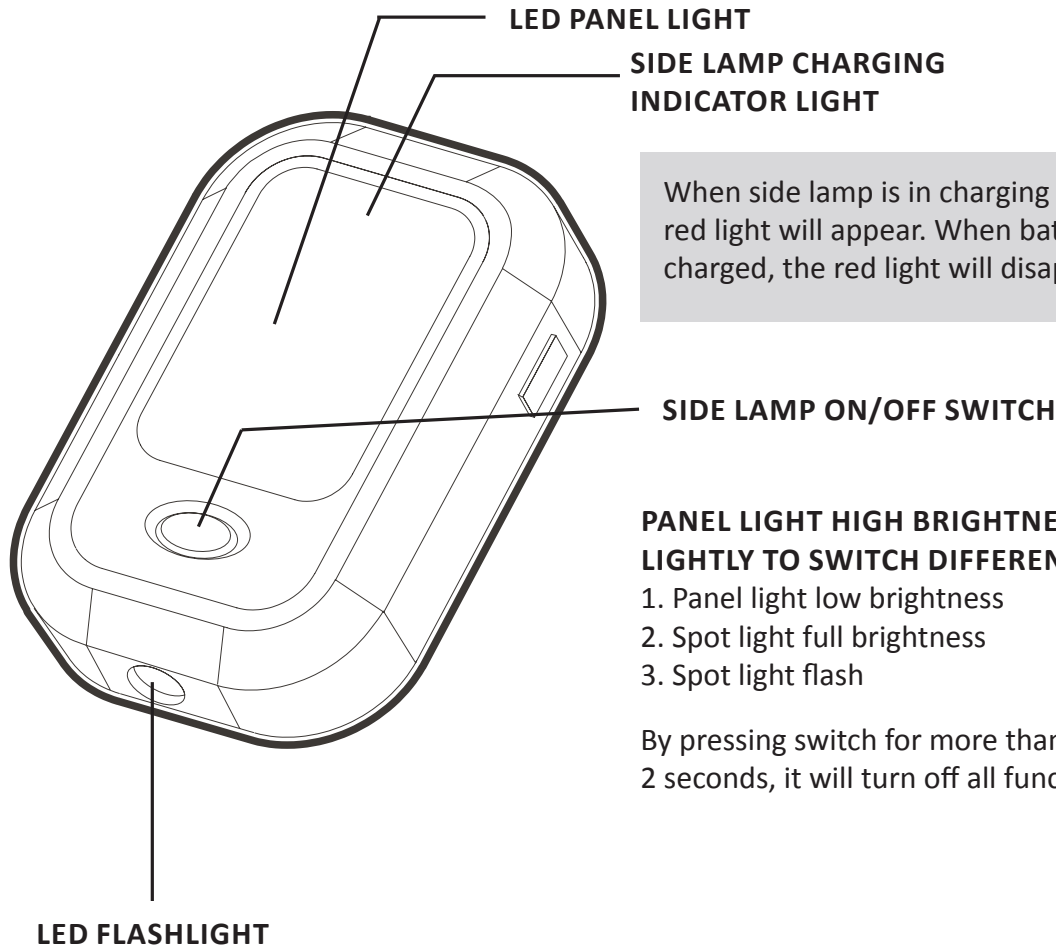

When side lamp is in charging mode, a red light will appear. When battery is fully charged, the red light will disappear.

**PANEL LIGHT HIGH BRIGHTNESS, THEN PRESS IT LIGHTLY TO SWITCH DIFFERENT FUNCTION IN ORDER:**

1. Panel light low brightness
2. Spot light full brightness
3. Spot light flash

By pressing switch for more than 2 seconds, it will turn off all functions.



Mosquito  
Repellent Light  
mode available

## SIDE LAMP CHARGING INTERFACE

(ATTACH IT TO THE MAIN LAMP)

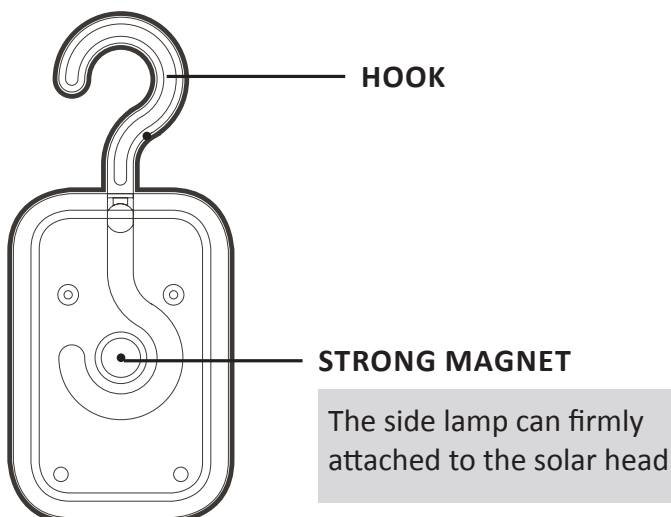

### SIDE LAMP CHARGING INSTRUCTIONS

1. The side lamp will be charged when attached to the charging port of main lamp while the battery is charging by DC input or solar power.
2. The side lamp has its own USB charging interface, also can use 5V charging adapter to charge it.
3. Please don't remove the side lamp for stable recharging while in charging condition.

## PORTABLE BLUETOOTH SPEAKER:

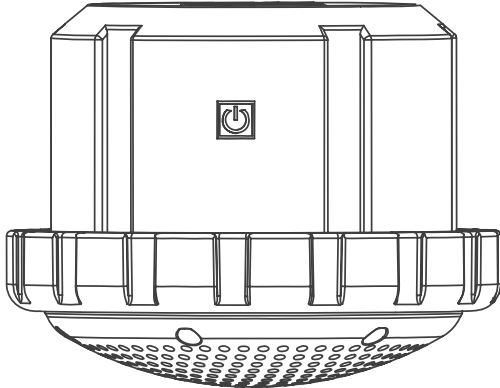

1. Press on/off switch for more than 5 sec. this will turn on the bluetooth speaker, connect the speaker (BT06) to your mobile device via bluetooth.

2. Holding on/off switch for 1-2 sec will pause the music

3. Indication lights:

Red: Charging

Green: Fully charged

Flashing blue: Start up

Solid blue: Bluetooth is connected

Blinking blue: In use

4. Integrated hook and magnet

**Attention: Bluetooth speaker does not charge on UFO, speaker needs to be charged using an external USB cord.**

## PARTS AND ACCESSORIES:

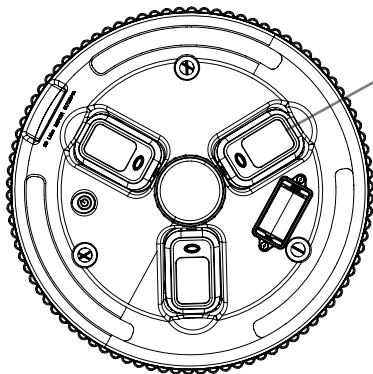

SIDE LAMP

MAIN LAMP

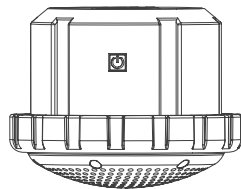

SPEAKER

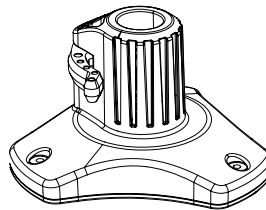

TRIPOD HEAD

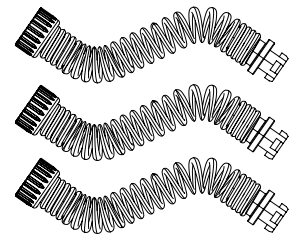

SPRING X 3



TRIPOD AXIS



SUPPORTING FEET X3

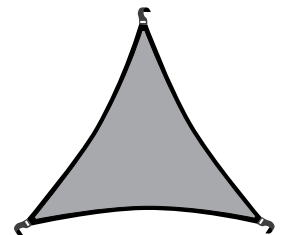

REINFORCEMENT BAG



TENT STAKE X3

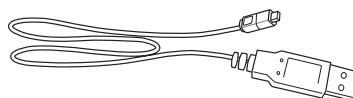

USB CHARGING CABLE



INSTRUCTION MANUAL



## INSTALLATION INSTRUCTIONS

### TRIPOD ASSEMBLING

1. Screw tight tripod legs into tripod base.

**\*\*Be careful to not strip the threads when installing the legs in to the tripod base. Be sure to line things up accordingly**

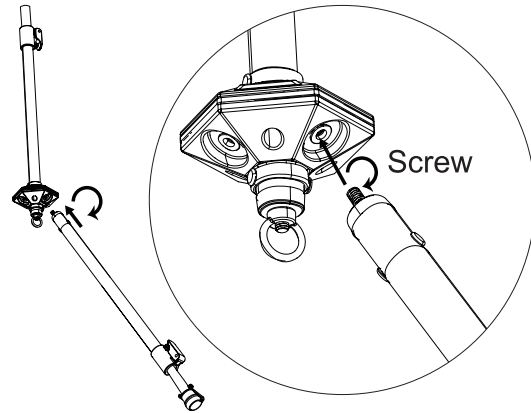

2. Tripod installation completed

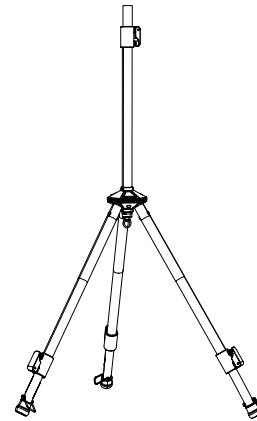

### TRIPOD ASSEMBLING

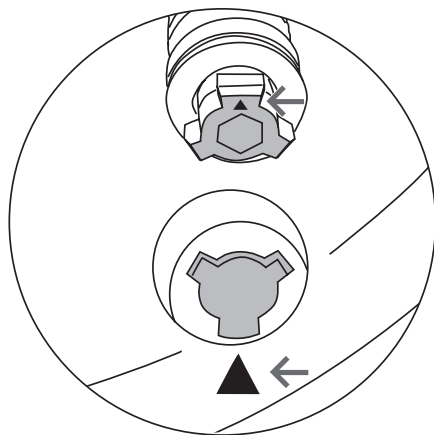

3. Install the springs into the sockets on the UFO lamp the springs have special key ways that need to be inserted into the UFO base.

Be careful to not strip the threads when installing the springs into the head unit. Be sure to line things up accordingly.

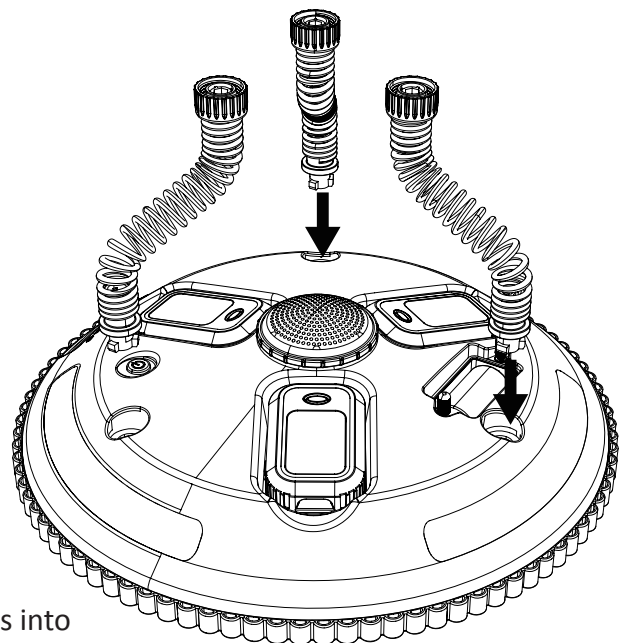

## TRIPOD HEAD ASSEMBLING

4. Screw tight tripod head with the spring.

**\*\*Be careful to not strip the threads when installing the springs in to the head unit. Be sure to line things up accordingly**

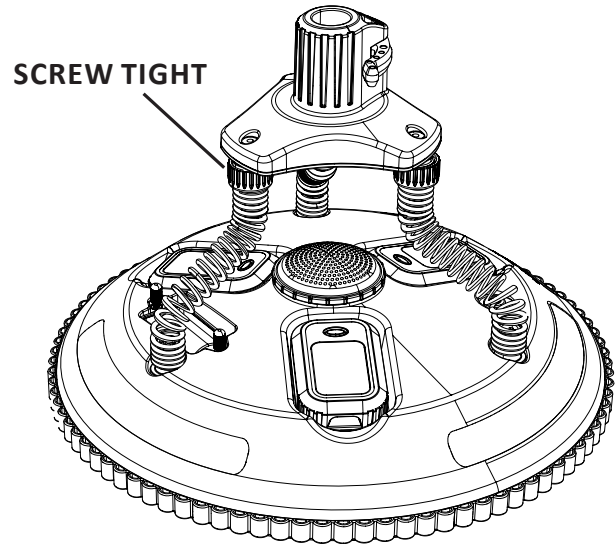

## COMPLETE ASSEMBLY

5. Open the safety lock then install the lamp into tripod and lock up.

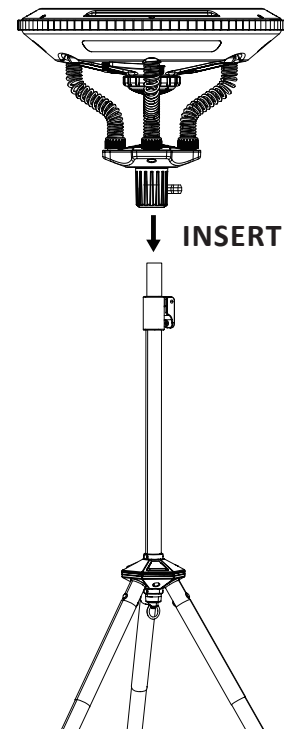
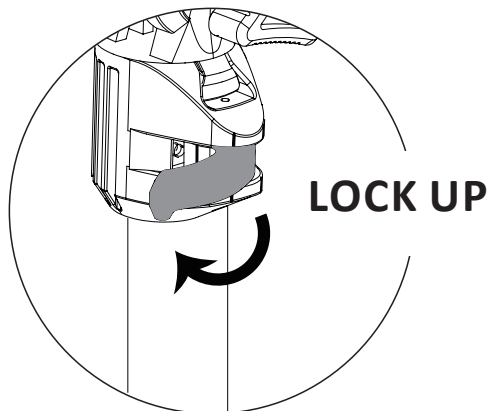

6. The tripod is adjustable up to 6.5 feet height via the safety lock

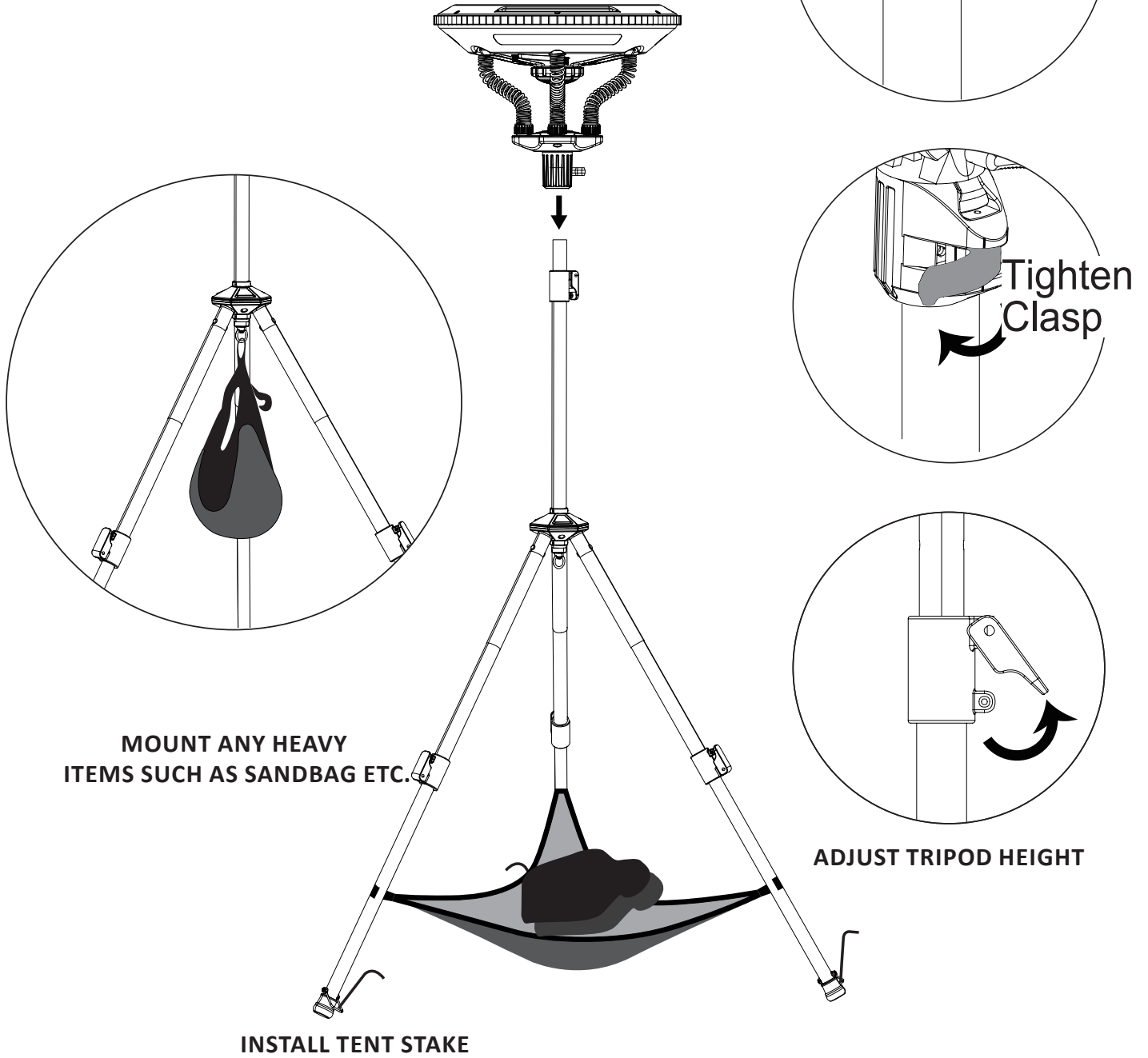

**REMARK:** Stakes are required for the tripod feet, and mounts heavy items under axis to be more stable under windy conditions.

# COMPONENTS USES

## 1. OUTDOOR

Provide better lighting for outdoor camping, parties etc.

## 2. USB POWER BANK

The lamp has integrated USB power bank function, it can provide electricity for mobile accessories via USB port (5V1A), the charging function will be turned off after 20 seconds if the accessory has been removed.

## 3. FLASHLIGHT AND MOSQUITO REPELLENT FUNCTION

The side lamp can be used as a standalone flashlight, and it comes with a Mosquito repellent function, great for outdoor enjoyment.

## 4. PORTABLE BLUETOOTH SPEAKER

The speaker can be operated via Bluetooth up to 33 feet distance, support a wide range of music formats, Great for outdoor enjoyment.

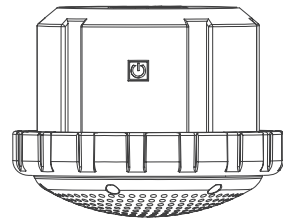
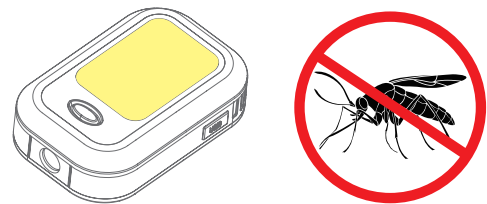
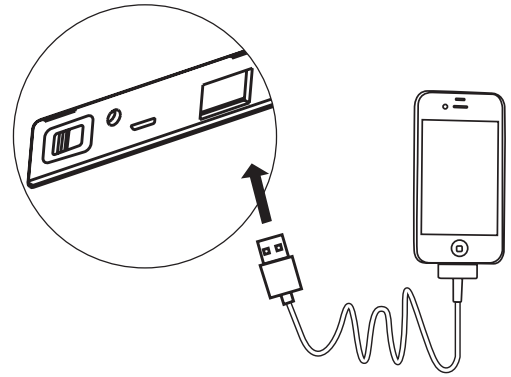

### Note:

1. Please use provided adaptors and cords to supply power to the unit and its components.
2. Secure tripod to floor when using.
3. This product uses rechargeable battery material that may contain chemicals that will pollute the environment. Please make sure that this product is recycled in a proper manner.
4. Recharge lamp periodically (once every 3 months) when stored for more than 3 months. Switching the battery operation mode to external battery will protect the lithium battery when not in use for long periods of time.
5. In a moving vehicle, always store the UFO Speaker/Lamp inside its storage container on the floor of the vehicle either behind the 1st row of seats or behind the 2nd row of seats.



Note: Please remove the dry battery from unit when not in use for long periods of time (battery may leak and cause serious damage to unit)



## DO YOU NEED OUR HELP?



CUSTOMER SUPPORT 833-226-4863



SALES@OVERLANDVEHICLESYSTEMS.COM

WANT TO SHOW US YOUR RIG?  
CHECK OUT OUR SOCIAL!

@overlandvehiclesystems

